

Modular Cooking Range Line thermaline 90 - 4 Zone Electric Solid Top with Ecotop, 2 Sides-Marine

ITEM # _____

MODEL # _____

NAME # _____

SIS # _____

AIA # _____

589873 (MCLDACJODM)

 Electric Solid Top, 4 zones,
 ecoTop coating, two-side
 operated - Marine

Short Form Specification

Item No.

Unit constructed according to DIN 18860_2 with 20 mm drop nose top and 70 mm recessed plinth. Internal frame for heavy duty sturdiness in stainless steel. 2 mm top in 1.4301 (AISI 304). Flat surface construction, easily cleanable. THERMODUL connection system enables seamless worktop when units are connected and avoids soil penetrating. ECOTOP model with a 20 mm thick steel cooking surface with heat retaining coating. 4 independently controlled heating zones with 2 electronic sensors per zone for temperature surface control and 8 power levels. Rapid plate heat up, continuously ready to use. Overheat protection switches off the supply in case of overheating. Standby function saves energy and quickly recovers maximum power. Metal knobs with embedded hygienic silicon "soft" grip enable easier handling and cleaning. IPX5 water resistance certification.

Configuration: Two-side operated top with backsplash. The base needs to be supplied by the factory. Please include appropriate base.

Main Features

- Rapid heat up of the plate and continuously ready for use.
- Overheat protection: the temperature sensor switches off the supply in case of overheating.
- Pans can easily be moved from one area to another without lifting.
- Wide rounded cleaning zone around the plates for easier cleaning.
- All major components may be easily accessed from the front.
- THERMODUL connection system creates a seamless work top when units are connected to each other thus avoiding soil penetrating vital components and facilitating the removal of units in case of replacement or service.
- Metal knobs with embedded hygienic "soft-touch" grip for easier handling and cleaning. The special design of the controls prevents infiltration of liquids or soil into vital components.
- Large visible digital display manufactured in tempered glass to resist heat and chemicals, showing temperatures or power settings. The display also shows on/off status of the appliance and on/off status of the heating elements.
- Cooking plate and base joint profile guarantee against soil infiltration.
- Two electronic sensors per zone to control surface temperature and to protect cooking plate from overheating.
- 8 power levels.
- ECOTOP model has a 20 mm thick steel DIN 1.7335 nickel coated cooking surface.
- 4 heating zones independently controlled.

Construction

- 2 mm top in 1.4301 (AISI 304).
- Flat surface construction with minimal hidden areas to easily clean all surfaces
- Internal frame for heavy duty sturdiness in 1.4301 (AISI 304).
- Unit constructed according to DIN 18860_2 with 20 mm drop nose top.
- IPX5 water resistance certification.
- Unit constructed according to DIN 18860_2 with 20 mm drop nose top and 70 mm recessed plinth.

Sustainability

- Standby function for energy saving and fast recovery of maximum power.



APPROVAL: _____



Electrolux
PROFESSIONAL

**Modular Cooking Range Line
thermaline 90 - 4 Zone Electric Solid
Top with Ecotop, 2 Sides-Marine**

Optional Accessories

- Wall mounting kit top - TL85/90 -
Factory Fitted

PNC 913654



**Modular Cooking Range Line
thermaline 90 - 4 Zone Electric Solid Top with Ecotop, 2 Sides-Marine**

The company reserves the right to make modifications to the products
without prior notice. All information correct at time of printing.

2026.04.14

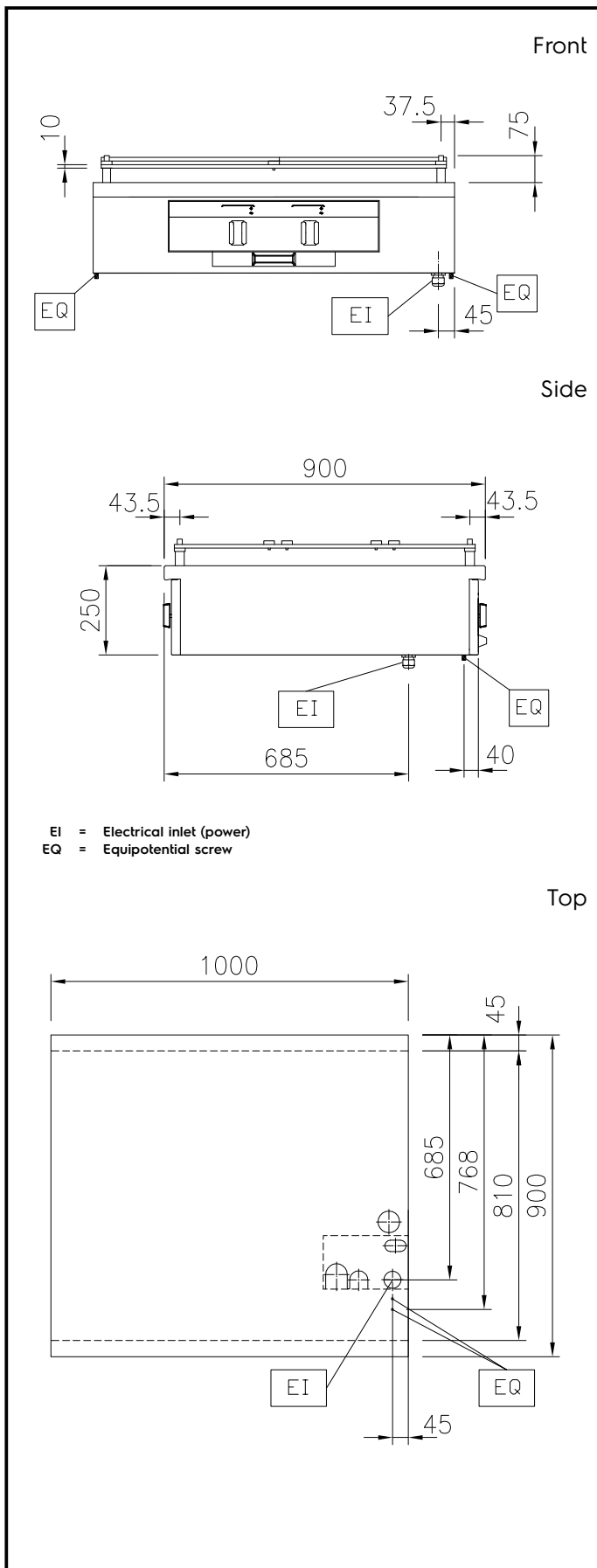

Electric

Supply voltage: 440 V/3 ph/50/60 Hz
Total Watts: 16 kW

Key Information:

Working Temperature MIN: 100 °C
Working Temperature MAX: 450 °C
External dimensions, Width: 1000 mm
External dimensions, Depth: 900 mm
External dimensions, Height: 250 mm
Net weight: 160 kg
Configuration: Two-Side Operated;Top
Front Plates Power: 4 - 4 kW
Back Plates Power: 4 - 4 kW
Solid top usable surface (width): 820 mm
Solid top usable surface (depth): 720 mm

Sustainability

Current consumption: 26 Amps